

High quality  
Leading technology  
Solution supplier



**HLS INDUSTRIAL SEWING MACHINE**

Distributor information:

VIOS SEWING MACHINERY CO.,LTD.  
Rm1102 ,LANE 7866 HUMIN ROAD,MINHANG DISTRICT,SHANGHAI,CHINA  
E-mail:huapu@viossewing.com,sales@viossewing.com

The functionality varies depending on the product model  
The information provided in this general catalogue may be changed by HLS without prior notice,  
and HLS reserves the right to interpret product parameters  
If model not inside,please ask us for separeated leaflet

**2026**  
GENERAL CATALOGUE

# 2026 PRODUCTS CATALOGUE

## NON-APPAREL SEWING MACHINE

General meaning of model letters:

M-for thin material(usually small hook)

H-for medium heavy material(usually small hook)

B-for heavy material(usually big hook)

C-edge cutter

CX-thick thread

D-automatic trimmer

DY-top and bottom feed

E-binding

L-long arm/left hook

LU-compound feed

R-right hook

T-puller

Q-pneumatic presser foot lifter

Z-direct drive

## GC0202 SERIES

DIRECT DRIVE SINGLE NEEDLE BOTTOM FEED LOCKSTITCH SEWING MACHINE

- Integrated direct drive,easy for install&energy saving;
- D4 With automatic thread nipper, automatic backtacking, automatic thread trimmer and electromagnet presser foot lifter;
- Q with pneumatic presser foot lifter.

GC0202	Integrated direct drive bottom feed lockstitch sewing machine
GC0202-D	Integrated direct drive bottom feed lockstitch sewing machine with trimmer(E-tension)
GC0202-D4	Integrated direct drive bottom feed lockstitch sewing machine with trimmer(EFL&E-tension)
GC0202-DQ	Integrated direct drive bottom feed lockstitch sewing machine with trimmer(PFL&E-tension)

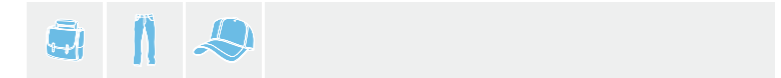

GC0202	•	•	3,200	0-8	DPX17 20#-23#	37	6.5/13	-	-	•	260X120
GC0202-D	•	•	3,200	0-8	DPX17 20#-23#	37	6.5/13	•	•	•	260X120
GC0202-D4	•	•	3,200	0-8	DPX17 20#-23#	37	6.5/13/12	•	•	•	260X120
GC0202-DQ	•	•	3,200	0-8	DPX17 20#-23#	37	6.5/13/12	•	•	•	260X120

## DY-352 SERIES

INTEGRATED INTELLIGENT TWO STEPPER TYPE TOP AND BOTTOM FEED LOCKSTITCH SEWING MACHINE

- Integrated direct drive, two stepper type;
- Stable structure and durability;
- Stepper motor control stitch length and presser foot lifter;
- Good ability for heavy duty and smooth stitches;

DY-352	Integrated intelligent one stepper top and bottom feed lockstitch sewing machine
--------	--



DY-352	•	•	2,500	0-8	DPX17 20#-23#	37	8/16	•	•	•	260X120

# GC0303Z/DY-350

INTEGRATED DIRECT DRIVE TOP AND BOTTOM FEED LOCKSTITCH SEWING MACHINE

- Integrated direct drive;
- Stable structure and durability;
- Low difference of reverse sewing due to link type feeding mechanism;
- Good ability for heavy duty and smooth stitches;
- C for edge cutter, E for binding;
- Edge cutter width 3.2,4.0,4.8mm specify when ordering.



GC0303Z	Integrated direct drive top and bottom feed lockstitch sewing machine
DY-350	Integrated direct drive top and bottom feed lockstitch sewing machine with automatic trimmer
DY-350C	Integrated direct drive top and bottom feed lockstitch sewing machine with edge cutter
DY-350CE	Integrated direct drive top and bottom feed lockstitch sewing machine with edge cutter and binder



GC0303Z	•	•	2,500	0-8	DPX17 20#-23#	37	7/16	-	-	•	260X120
DY-350	•	•	2,500	0-8	DPX17 20#-23#	37	8/16/13	•	•	•	260X120
DY-350C	•	•	2,500	0-8	DPX17 20#-23#	37	8/16/13	•	•	•	260X120
DY-350CE	•	•	2,500	0-8	DPX17 20#-23#	37	8/16/13	•	•	•	260X120

# DY-860 SERIES

DIRECT DRIVE TOP AND BOTTOM FEED WITH PRESSER FOOT REGULATOR LOCKSTITCH SEWING MACHINE

- Integrated direct drive;
- Large working space with presser foot alternation dial;
- Max.Stitch length 8mm(Optional 12mm);
- Optional PFL/EFL.

DY-860	Direct drive top and bottom feed lockstitch sewing machine
DY-860C	Direct drive top and bottom feed lockstitch sewing machine with edge cutter



DY-860	•	•	2,400	0-8	DPX17 16#-23#	38	7/17	•	•	•	330X120
DY-860C	•	•	2,400	0-8	DPX17 16#-23#	38	7/17	•	•	•	330X120



# GC0628/-DZ

SINGLE NEEDLE DIRECT DRIVE COMPOUND FEED LOCKSTITCH SEWING MACHINE

- DZ with Integrated direct drive;
- Specially designed for heavy duty;
- Competitive price and widely welcome by market;
- With automatic oil lubrication;
- Strong compound feeding system,excellent sewing effect.



GC0628	Single needle compound feed lockstitch sewing machine
GC0628-DZ	Single needle direct drive compound feed lockstitch sewing machine

GC0628/-DZ	•	•	2,000	0-10	DPX17 22#-24#	35	8/14	-	-	•	265X110
------------	---	---	-------	------	------------------	----	------	---	---	---	---------

# GC20638 SERIES

DOUBLE NEEDLE SPLIT NEEDLE BAR COMPOUND FEED LOCKSTITCH SEWING MACHINE

- Corner sewing,split needle bar;
- Ball bearing for arm and lower shaft,cog belt driving;
- Z with direct drive,D for trimmer,Q for PFL;
- Suitable for car seat,safety belt,jumbo bag,tents,parachutes,gliding parachutes,sofa,sailing etc.,
- Needle gauge,standard:8mm, special 6.4mm,9.5mm,12.7mm;
- Specify when ordering.



GC20638-Z	Direct drive double needle split needle bar compound feed lockstitch sewing machine
GC20638-DQZ	Direct drive double needle split needle bar compound feed lockstitch sewing machine with automatic trimmer and PFL

GC20638-Z	•	•	2,000	0-9	DPX17 23#	33.4	7/13	-	-	•	254X100
GC20638-DQZ	•	•	2,000	0-9	DPX17 23#	33.4	7/13	•	•	•	254X100

# GC20698 SERIES

LONG ARM COMPOUND FEED LOCKSTITCH SEWING MACHINE

- Long arm(635mm);
- D trimmer,Q for PFL;
- Bobbin winder on top of machine;
- Suitable for car seat,safety belt,tent,parachute,sails etc.,
- For double needles:Standard needle gauge:6.4mm,Optional: 3.2,4.8,8,9.5,12.7,16,19,25.4mm
- Specify when ordering



GC20698-1	25inches long arm single needle compound feed lockstitch sewing machine
GC20698-1D	25inches long arm single needle compound feed lockstitch sewing machine with automatic trimmer
GC20698-1DQ	25inches long arm single needle compound feed lockstitch sewing machine with automatic trimmer(PFL)
GC20698-2	25inches long arm double needle compound feed lockstitch sewing machine
GC20698-2D	25inches long arm double needle compound feed lockstitch sewing machine with automatic trimmer
GC20698-2DQ	25inches long arm double needle compound feed lockstitch sewing machine with automatic trimmer(PFL)



	•	•	1,800	0-9	DPX17 18#-23#	36	9/16	-	-	•	635X100
GC20698-1	•	•	1,800	0-9	DPX17 18#-23#	36	9/16	•	•	•	635X100
GC20698-1D	•	•	1,800	0-9	DPX17 18#-23#	36	9/16	•	•	•	635X100
GC20698-1DQ	•	•	1,800	0-9	DPX17 18#-23#	36	9/16	•	•	•	635X100
GC20698-2	•	•	1,800	0-9	DPX17 18#-23#	36	9/16	-	-	•	635X100
GC20698-2D	•	•	1,800	0-9	DPX17 18#-23#	36	9/16	•	•	•	635X100
GC20698-2DQ	•	•	1,800	0-9	DPX17 18#-23#	36	9/16	•	•	•	635X100

# GC20698-5/6/7/8

20INCHES/30INCHES LONG ARM COMPOUND FEED LOCKSTITCH SEWING MACHINE

- Sliding bars for thread taking-up;
- Needle bearing for arm shaft, cog belt driving;
- Suitable for car seat, safety belt, safety air bag, tent, parachutes, etc;
- T with puller;
- Standard with servo motor(750W);
- Full function pedal optional;
- Standard needle gauge 19mm;
- Optional: 6.4, 9.5, 12.7, 22, 25, 31.8, 44.5mm;
- Specify when ordering.

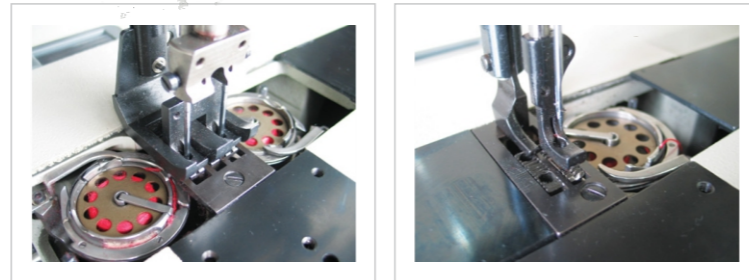
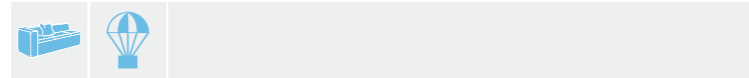

GC20698-5	20inches long arm single needle compound feed lockstitch sewing machine
GC20698-5T	20inches long arm single needle compound feed lockstitch sewing machine(with puller)
GC20698-6	20inches long arm double needle compound feed lockstitch sewing machine
GC20698-6T	20inches long arm double needle compound feed lockstitch sewing machine(with puller)
GC20698-7	30inches long arm single needle compound feed lockstitch sewing machine
GC20698-7T	30inches long arm single needle compound feed lockstitch sewing machine(with puller)
GC20698-8	30inches long arm double needle compound feed lockstitch sewing machine
GC20698-8T	30inches long arm double needle compound feed lockstitch sewing machine(with puller)



GC20698-5	•	•	1,200	0-10	DYX3 26#	47.3	20/28	-	-	•	508X145
GC20698-5T	•	•	1,200	0-10	DYX3 26#	47.3	28	-	•	•	508X145
GC20698-6	•	•	1,200	0-10	DYX3 26#	47.3	20/28	-	-	•	508X145
GC20698-6T	•	•	1,200	0-10	DYX3 26#	47.3	28	-	•	•	508X145
GC20698-7	•	•	1,200	0-10	DYX3 26#	47.3	20/28	-	-	•	762X145
GC20698-7T	•	•	1,200	0-10	DYX3 26#	47.3	28	-	•	•	762X145
GC20698-8	•	•	1,200	0-10	DYX3 26#	47.3	20/28	-	-	•	762X145
GC20698-8T	•	•	1,200	0-10	DYX3 26#	47.3	28	-	•	•	762X145

# GC20518 SERIES

TWIN NEEDLE HIGH SPEED NEEDLE FEEDING LOCKSTITCH SEWING MACHINE

- NO. 1 in China of double needle machine for outdoor sport goods;
- GC20518-BZ Most popular in China famous tent factories;
- Needle bar and feed dog feed synchronously, ensuring better stitch;
- Z for direct drive, M for thin(H for medium heavy, hook same as M), B for big hook for heavy duty, D for automatic thread trimmer;
- EFL/PFL optional;
- Needle gauge: standard 6.4mm;
- Special: 2.4, 3.2, 4.4, 8.5, 6.8, 9.5, 12.7, 16, 19, 25.4, 28.6, 32, 38mm;
- Specify when ordering.



GC20518-M	Twin needle high speed needle feeding lockstitch sewing machine(small hook)
GC20518-B	Twin needle high speed needle feeding lockstitch sewing machine(big hook)
GC20518-MZ	Direct drive twin needle high speed needle feeding lockstitch sewing machine(small hook)
GC20518-BZ	Direct drive twin needle high speed needle feeding lockstitch sewing machine(big hook)
GC20518-MD	Twin needle high speed needle feeding lockstitch sewing machine with automatic trimmer(small hook)
GC20518-BD	Twin needle high speed needle feeding lockstitch sewing machine with automatic trimmer(big hook)
GC20518-MDZ	Direct drive twin needle high speed needle feeding lockstitch sewing machine with automatic trimmer (small hook)
GC20518-BDZ	Direct drive twin needle high speed needle feeding lockstitch sewing machine with automatic trimmer (big hook)

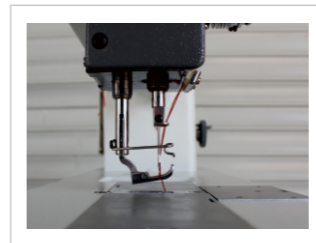

GC20518-M	•	•	4,000	0-5	DPX5 11#-14#	33.4	7/13	-	-	•	-	250x100
GC20518-B	•	•	3,000	0-7	DPX5 18#-22#	35	7/13	-	-	-	•	250x100
GC20518-MZ	•	•	4,000	0-5	DPX5 11#-14#	33.4	7/13	-	-	•	-	250x100
GC20518-BZ	•	•	3,000	0-7	DPX5 18#-22#	35	7/13	-	-	-	•	250x100
GC20518-MD	•	•	4,000	0-5	DPX5 11#-14#	33.4	7/13	•	•	•	-	250x100
GC20518-BD	•	•	3,000	0-7	DPX5 18#-22#	35	7/13	•	•	-	•	250x100
GC20518-MDZ	•	•	4,000	0-5	DPX5 11#-14#	33.4	7/13	•	•	•	-	250x100
GC20518-BDZ	•	•	3,000	0-7	DPX5 18#-22#	35	7/13	•	•	-	•	250x100

# GC20528 SERIES

TWIN NEEDLE SPLIT NEEDLE BAR HIGH SPEED LOCKSTITCH SEWING MACHINE

- NO.1 in China of double needle machine for outdoor sport goods;
- Z for direct drive, M for thin (H for medium heavy, hook same as M), B for big hook for heavy duty, D for automatic thread trimmer;
- Two separated needle bars make easier for corner sewing;
- EFL/PFL optional for D models;
- Needle gauge, standard: 6.4mm, special: 2.4, 3.2, 4, 4.8, 5.6, 8, 9.5, 12.7mm;
- Specify when ordering.

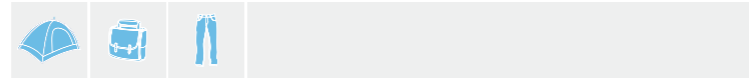

GC20528-BDZ

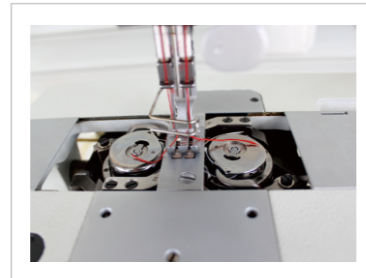

GC20528-M	Twin needle split needle bar high speed lockstitch sewing machine (small hook)
GC20528-B	Twin needle split needle bar high speed lockstitch sewing machine (big hook)
GC20528-MZ	Direct drive twin needle split needle bar high speed lockstitch sewing machine (small hook)
GC20528-BZ	Direct drive twin needle split needle bar high speed lockstitch sewing machine (big hook)
GC20528-MD	Twin needle split needle bar high speed lockstitch sewing machine with automatic trimmer (small hook)
GC20528-BD	Twin needle split needle bar high speed lockstitch sewing machine with automatic trimmer (big hook)
GC20528-MDZ	Direct drive twin needle split needle bar high speed lockstitch sewing machine with automatic trimmer (small hook)
GC20528-BDZ	Direct drive twin needle split needle bar high speed lockstitch sewing machine with automatic trimmer (big hook)

	MAX	mm	mm	mm	mm	mm	mm	mm	mm	mm	mm	
GC20528-M	•	•	3,500	0-5	DPX5 11#-14#	33.4	7/13	-	-	•	-	250X100
GC20528-B	•	•	3,000	0-7	DPX5 18#-22#	33.4	7/13	-	-	-	•	250X100
GC20528-MZ	•	•	3,500	0-5	DPX5 11#-14#	33.4	7/13	-	-	•	-	250X100
GC20528-BZ	•	•	3,000	0-7	DPX5 18#-22#	33.4	7/13	-	-	-	•	250X100
GC20528-MD	•	•	3,500	0-5	DPX5 11#-14#	33.4	7/13	•	•	•	-	250X100
GC20528-BD	•	•	3,000	0-7	DPX5 18#-22#	33.4	7/13	•	•	-	•	250X100
GC20528-MDZ	•	•	3,500	0-5	DPX5 11#-14#	33.4	7/13	•	•	•	-	250X100
GC20528-BDZ	•	•	3,000	0-7	DPX5 18#-22#	33.4	7/13	•	•	-	•	250X100

# GA0688-1 SERIES

EXTRA HEAVY DUTY COMPOUND FEED LOCKSTITCH SEWING MACHINE

- Semi-rotary large shuttle hook for large thread capacity;
- Up to 20mm presser foot lifting adaptable for extra heavy duty material;
- Big operation space 405X167mm, wide usage.



GA0698

GA0688-1	Extra heavy duty compound feed lockstitch sewing machine
GA0688-1C	Extra heavy compound feed lockstitch sewing machine (with edge cutter)

	MAX	mm	mm	mm	mm	mm	mm	mm	mm	mm	mm
GA0698	•	•	8,00	0-15	DPX3 24#-27#	56	13/20	-	-	•	405X167
GA0698-C	•	•	8,00	0-15	DPX3 24#-27#	56	13/20	-	-	•	405X167

# GC24018 SERIES

BOTTOM FEEDING POST BED LOCKSTITCH SEWING MACHINE

- Feed dog feeding, design for cap, wig, shoes, leather bag, glove, etc;
- A with flat presser foot;
- GC24018-1 needle gauge 2.4mm, optional 3.2mm and 4mm;
- Post bed height: 178mm.

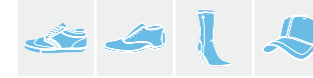

GC24018-1

Gc24018	Single needle roller presser foot bottom feeding post bed lockstitch sewing machine
GC24018-1	Double needle roller presser foot bottom feeding post bed lockstitch sewing machine
GC24018-A	Single needle flat presser foot bottom feeding post bed lockstitch sewing machine (wig ball optional)



GC24018-A with ball for wig

	MAX	mm	mm	mm	mm	mm	mm	mm	mm	mm	mm
GC24018	•	•	3,000	0-4	DPX5 14#-18#	33.4	7/10	-	-	•	250X178
GC24018-1	•	•	3,000	0-4	DPX5 14#-18#	33.4	5/7.5	-	-	•	250X178
GC24018-A	•	•	3,000	0-4	DPX5 14#-18#	33.4	7/10	-	-	•	250X178

# GC24518 SERIES

NEEDLE FEEDING LOCKSTITCH SEWING MACHINE

- Widely use on cap,needle feeding;
- Standard equipped with flat presser foot for cap;
- Full optional device:tape feeding,tape cutter,etc;
- D for trimmer,GC24518-1RDZ with perfect functions with good feeding&trimmer due to design construction

GC24518-1Z	Direct drive single needle needle feeding lockstitch sewing machine
GC24518-1RDZ	Direct drive single needle needle feeding lockstitch sewing machine with automatic trimmer(Right hook)
GC24518-2DZ	Direct drive double needles needle feeding lockstitch sewing machine with automatic trimmer



GC24518-1Z with tape cutter



GC24518-1RDZ with tape cutter



GC24518-1Z



GC24518-1RDZ



GC24518-2DZ



GC24518-1Z	•	•	2,500	0-5	DPX5 11#-14#	33.4	7/10	-	-	•	-	405X167
GC24518-1RDZ	•	•	3,000	0-5	DPX5 11#-22#	36	10	•	•	•	-	405X167
GC24518-2DZ	•	•	2,500	0-5	DPX5 11#-22#	36	10	•	•	•	-	405X167

# GC24608 SERIES

HIGH POST COMPOUND FEED LOCKSTITCH SEWING MACHINE

- Classic design high post compound feed lockstitch;
- Widely use on car seat ,bag/luggage,boots,etc
- Post bed height:178mm
- Double needle needle gauge:  
Standard 8mm,9.5mm  
Special:4.8mm,6.4mm,12.7mm  
Specify when ordering
- GC24608-2Q-18Z 18inches long arm;  
Suitable for sofa, car seat mat, etc;  
Direct drive,PFL,auto backtacking;  
Standard needle gauge 8mm,optional:9.5mm



GC24608-2Q



GC24608-2Q-18Z

GC24608-1L/1R	Single needle high post compound feed lockstitch sewing machine(L for left hook,R for right hook)
GC24608-1LD/1RD	Single needle high post compound feed lockstitch sewing machine with trimmer(L for left hook,R for right hook)(PFL)
GC24608-2	Twin needle high post compound feed lockstitch sewing machine
GC24608-2Z	Direct drive twin needle high post compound feed lockstitch sewing machine
GC24608-2Q	Twin needle high post compound feed lockstitch sewing machine(PFL)
GC24608-2QZ	Direct drive twin needle high post compound feed lockstitch sewing machine(PFL)
GC24608-2DZ	Direct drive twin needle high post compound feed lockstitch sewing machine with automatic trimmer (PFL)
GC24608-2Q-18Z	Direct drive high post double needle 18inches long arm compound feed lockstitch sewing machine(PFL)



GC24608-1L/1R	•	•	2,000	0-7	DPX17 22#-24#	36	8/16	-	-	•	250X178
GC24608-1LD/1RD	•	•	2,000	0-7	DPX17 22#-24#	36	8/16	•	•	•	250X178
GC24608-2	•	•	2,000	0-7	DPX17 22#-24#	36	8/16	-	-	•	250X178
GC24608-2Z	•	•	2,000	0-7	DPX17 22#-24#	36	8/16	-	-	•	250X178
GC24608-2Q	•	•	2,000	0-7	DPX17 22#-24#	36	16	-	•	•	250X178
GC24608-2QZ	•	•	2,000	0-7	DPX17 22#-24#	36	16	-	•	•	250X178
GC24608-2DZ	•	•	2,000	0-7	DPX17 22#-24#	36	16	•	•	•	250X178
GC24608-2Q-18Z	•	•	2,000	0-9	DPX17 22#-24#	36	16	-	•	•	457x178



# GC246 SERIES

SINGLE NEEDLE CYLINDER BED COMPOUND FEEDING LOCKSTITCH SEWING MACHINE

- Small cylinder with strong feed;
- Auto oil lubrication;
- Two times hook;
- Beautiful and efficient stitches;
- Model with E means with synchronized binder,Z direct drive;
- Cylinder bed diameter:50mm.



GC246	Single needle cylinder bed compound feeding lockstitch sewing machine
GC246Z	Direct drive single needle cylinder bed compound feeding lockstitch sewing machine
GC246E	Single needle cylinder bed compound feeding lockstitch sewing machine with synchronized binder
GC246EZ	Direct drive single needle cylinder bed compound feeding lockstitch sewing machine with synchronized binder

	MAX	Stitch	Speed	Needle	Presser	Foot	Scissors	Reverse	Auto	mm	
GC246	•	•	2,500	0-6	DPX17 14#-18#	33.4	5/15	-	-	•	257X110
GC246Z	•	•	2,500	0-6	DPX17 14#-18#	33.4	5/15	-	-	•	257X110
GC246E	•	•	2,500	0-6	DPX17 14#-18#	33.4	5/15	-	-	•	257X110
GC246EZ	•	•	2,500	0-6	DPX17 14#-18#	33.4	5/15	-	-	•	257X110

# GC-P335 SERIES

SINGLE NEEDLE CYLINDER BED COMPOUND FEEDING LOCKSTITCH SEWING MACHINE

- Compound feed,,stable feeding;
- Diameter 46mm(167),50mm(P335-B),flexible turning when binding;
- Model with E for synchronous horizontal feeding with binder;
- Suitable for cylinder and curved articles;
- E for binding,B for big hook.



GC-P335	Single needle cylinder bed compound feeding lockstitch sewing machine
GC-P335-E	Single needle cylinder bed compound feeding lockstitch sewing machine with synchronized binder
GC-P335-B	Single needle cylinder bed compound feeding lockstitch sewing machine (big hook)
GC-P335-BE	Single needle cylinder bed compound feeding lockstitch sewing machine with synchronized binder(big hook)

	MAX	Stitch	Speed	Needle	Presser	Foot	Scissors	Reverse	Auto	mm	
GC-P335	•	•	2,200	0-6	DPX17 16#-18#	33.2	5/15	-	-	•	258X110
GC-P335-E	•	•	2,200	0-6	DPX17 16#-18#	33.2	5/15	-	-	•	258X110
GC-P335-B	•	•	2,200	0-7	DPX17 18#-23#	33.2	5/15	-	-	•	258X110
GC-P335-BE	•	•	2,200	0-7	DPX17 18#-23#	33.2	5/15	-	-	•	258X110

# HLS-0605/0906

ELECTRONIC PATTERN SEWING MACHINE

- Standard with touching screen, suitable for small patterns, efficiency more than 15% higher

HLS-0605	Electronic pattern sewing machine(6×5cm)
HLS-0906	Electronic pattern sewing machine(9×6cm)



	MAX	Stitch	Speed	Needle	Presser	Foot	Scissors	Reverse	Auto	mm	
HLS-0605	•	•	3,000	0.5-12.7	DP*5 16	41.2	17	•	-	•	60X50
HLS-0906	•	•	3,000	0.5-12.7	DP*5 16	41.2	17	•	-	•	90X60

# HLS-G3520R-A SERIES

ELECTRONIC PATTERN SEWING MACHINE

- Classic Mitsubishi type;
- Dahao separated new control system; Touching screen, easy and quick for pattern programming;
- Taiwan guider;
- Support USB disk input;
- MITSUBISHI type, easy operation and maintenance;
- Hook;
- Optional: thread broken inspection, double tension, sliding/rotating presser foot device, cap visor device, three times hook, etc.

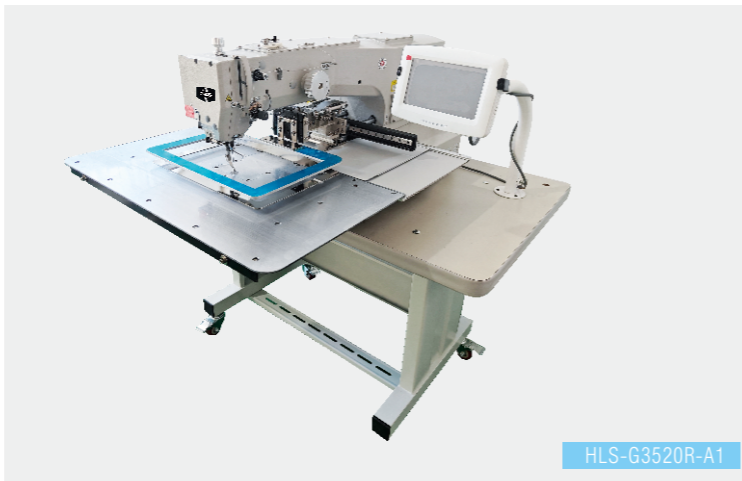

HLS-G3520R-A1

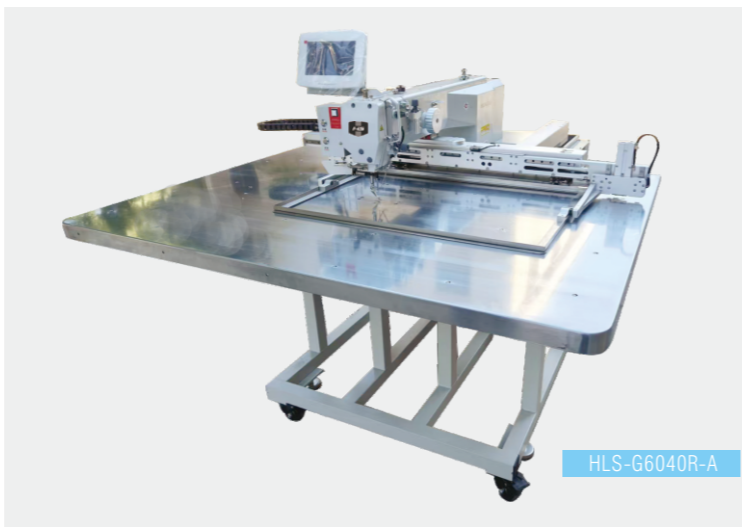

HLS-G6040R-A

HLS-G3520R-A	Electronic pattern sewing machine(35×20cm)
HLS-G3520R-A1	Electronic pattern sewing machine(35×20cm) (European design)
HLS-G4030R-A	Electronic pattern sewing machine(40×30cm)
HLS-G5030R-A	Electronic pattern sewing machine(50×30cm)
HLS-G6040R-A	Electronic pattern sewing machine(60×40cm)



	MAX	DP	Needle	Foot	Scissors	mm
HLS-G3520R-A	• 3,000	0.05-12.7	DP*17 16-23	40	25	• 350x200
HLS-G3520R-A1	• 3,000	0.05-12.7	DP*17 16-23	40	25	• 350x200
HLS-G4030R-A	• 2,500	0.05-12.7	DP*17 16-23	40	25	• 400x300
HLS-G5030R-A	• 2,500	0.05-12.7	DP*17 16-23	40	25	• 500x300
HLS-G6040R-A	• 2,500	0.05-12.7	DP*17 16-23	40	25	• 600x400

# HLS-326G SERIES

ELECTRONIC PATTERN SEWING MACHINE

- Classic Brother type;
- Dahao separated new control system, Touching-screen, easy and quick for pattern programming;
- Taiwan guider;
- Support USB disk input;
- Shuttle hook, flat blade pull rod and simple trimmer structure, shorter trimmer ending, Dual axis feeding instruction, 7pcs feeding guide rails;
- Optional: thread broken inspection, double tension, sliding/rotating presser foot device, cap visor device, etc.

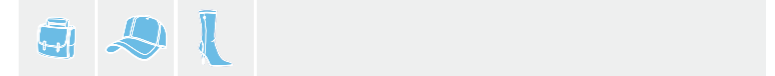

HLS-326G

HLS-311G	Electronic pattern sewing machine(13×10cm)
HLS-326G	Electronic pattern sewing machine(22×10cm)
HLS-342G	Electronic pattern sewing machine(30X20cm)
HLS-352G	Electronic pattern sewing machine(40×30cm)
HLS-364G	Electronic pattern sewing machine(60×40cm)



HLS-342G

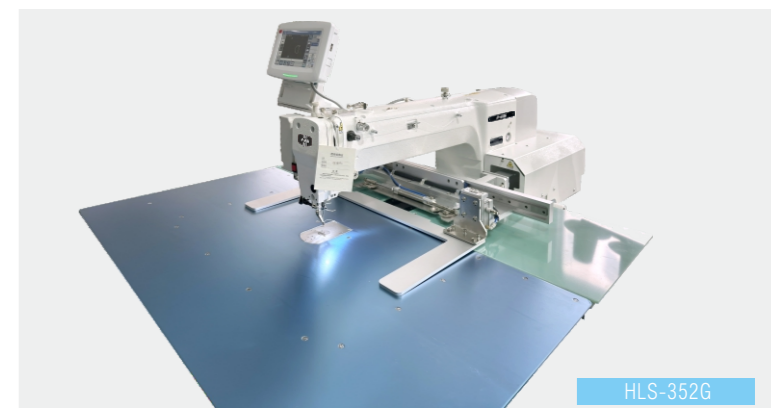

HLS-352G



	MAX	DP	Needle	Foot	Scissors	mm
HLK-311G	• 2,800	0.5-12.7	DP*17 18	41.2	30	• 130X100
HLK-326G	• 2,800	0.5-12.7	DP*17 18	41.2	30	• 220X100
HLK-342G	• 2,800	0.5-12.7	DP*17 18	41.2	30	• 300X200
HLK-352G	• 2,800	0.5-12.7	DP*17 18	41.2	30	• 400X300
HLK-364G	• 2,800	0.5-12.7	DP*17 18	41.2	30	• 600X400

# HLS-430 SERIES

ELECTRONIC BARTACKING AND PUNCHING SEWING MACHINE

- HLK-430 bartacking machine, Adopting a fully closed stepper motor for more stable feeding, The X direction can achieve 5CM bartacking;
- HLK-430-MO: Can make round eyes with inner holes of 1.5-8mm and double cylinder design for knitting without material jamming;
- HLK-430-MOC: Automatic Stepper motor bottom material feeding device, more saturated cap eyes, suitable for high demand production process.

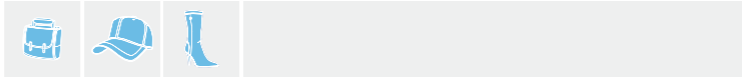

HLS-430

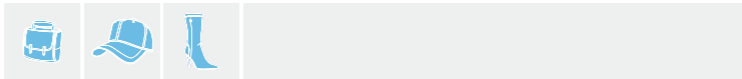

HLS-430-DS



HLS-430	•	•	3,200	0.5-12.7	DP*5 16	41.2	17	•	-	•
HLS-430MO	-	•	3,200	0.5-12.7	DP*5 16	41.2	17	•	-	•
HLS-430MOC	-	•	3,200	0.5-12.7	DP*5 16	41.2	17	•	-	•

# GG-110/810/820/830 SERIES

ZIGZAG SEWING MACHINE

- Z direct drive, B big hook, D trimmer, 810, 820, 830 top and bottom feed;
- Compensation stitch switch, LED lighting for easier operation;
- Direct pump oil supply effectively lubricates, reduces noise, and minimizes wear and tear.



GG-110-Z	Direct drive single needle heavy duty zigzag sewing machine
GG-110-DZ	Direct drive single needle heavy duty zigzag sewing machine with automatic trimmer
GG-810-Z	Direct drive single needle heavy duty top and bottom feeding zigzag sewing machine(big hook)
GG-820-EZ	Direct drive single needle top and bottom feed cylinder bed zigzag sewing machine
GG-830-NZ	Post bed stepper type single needle top and bottom feeding zigzag sewing machine



GG-810-BZ



GG-820-EZ



GG-110-DZ



GG-830-NZ

GG-110-Z	•	-	2,200	0-4	DPX5 12#-18#	34	6/12	-	-	•	260X115
GG-110-DZ	•	-	2,200	0-4	DPX5 12#-18#	34	6/12	•	•	•	260X115
GG-810-Z	-	•	2,000	0-5	DPX5 16#-23#	35	8/15	-	-	•	260X115
GG-820-EZ	-	•	2,000	0-4	DPX5 14#-18#	35	8/15	-	-	•	260X115
GG-830-NZ	-	•	2,000	0-5	DPX5 14#-18#	35	6/12	-	-	•	260X190

# GG0028 SERIES

ZIGZAG SEWING MACHINE



- Germany style design, feed dog feeding;
- D with automatic trimmer, Z direct drive, F with changing cam, L for long arm;
- Widely use on medium heavy duty articles, such as shoes, bag, canvas goods, leather goods, sofa, etc;
- Model F, standard cam No.02, specify when ordering if need special pattern.

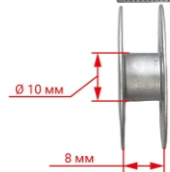
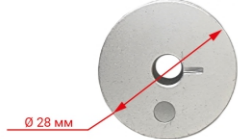

缝紉花樣  
Stitch patterns

01 02 03 04 05 06 07

08 09 10 11 12 13 14

GG0028-1	Single needle medium-heavy duty zigzag sewing machine
GG0028-1DZ	Direct drive single needle medium-heavy duty zigzag sewing machine with automatic trimmer
GG0028-1D	Single needle medium-heavy duty zigzag sewing machine with automatic trimmer
GG0028-1L	Single needle long arm zigzag sewing machine
GG0028-1LD	Single needle long arm medium-heavy duty zigzag sewing machine with automatic trimmer
GG0028-2	Twin needle medium-heavy duty zigzag sewing machine
GG0028-2D	Twin needle medium-heavy duty zigzag sewing machine with automatic trimmer
GG0028-1F	Single needle medium-heavy duty fancy pattern zigzag sewing machine (Cam Type 2)
GG0028-1FD	Single needle medium-heavy duty fancy pattern zigzag sewing machine with automatic trimmer (Cam Type 2)
GG0028-1FDZ	Direct drive single needle medium-heavy duty fancy pattern zigzag sewing machine with automatic trimmer (Cam Type 2)
GG0028-1FL	Single needle medium-heavy duty long arm fancy pattern zigzag sewing machine (Cam Type 2)
GG0028-1FLD	Single needle medium-heavy duty long arm fancy pattern zigzag sewing machine with automatic trimmer (Cam Type 2)

GG0028-1	•	•	2,200	0-5	DPX35 12#-18#	36	7/13	-	-	•	•	•	260X115
GG0028-1DZ	•	•	2,200	0-5	DPX35 12#-18#	36	7/13	•	•	•	•	•	260X115
GG0028-1D	•	•	2,200	0-5	DPX35 12#-18#	36	7/13	•	•	•	•	•	260X115
GG0028-1L	•	•	1,400	0-5	DPX35 12#-18#	36	7/13	-	-	•	•	•	735X115
GG0028-1LD	•	•	1,400	0-5	DPX35 12#-18#	36	7/13	•	•	•	•	•	735X115
GG0028-2	•	•	2,200	0-5	DPX35 12#-18#	36	7/13	-	-	•	•	•	260X115
GG0028-2D	•	•	2,200	0-5	DPX35 12#-18#	36	7/13	•	•	•	•	•	260X115
GG0028-1F	•	•	2,200	0-5	DPX35 12#-18#	36	7/12	-	-	•	•	•	260X115
GG0028-1FD	•	•	2,200	0-5	DPX35 12#-18#	36	7/12	•	•	•	•	•	260X115
GG0028-1FDZ	•	•	1,400	0-5	DPX35 12#-18#	36	7/12	•	•	•	•	•	260X115
GG0028-1FL	•	•	1,400	0-5	DPX35 12#-18#	36	7/12	-	-	•	•	•	735X115
GG0028-1FLD	•	•	1,400	0-5	DPX35 12#-18#	36	7/12	•	•	•	•	•	735X115

# YXP-18/28

## SKIVING MACHINE

- Equipped with automatic chip cleaner and knife sharpening clutch;
- YXP-28 for top and bottom feeding;
- Max. skiving width is 50mm;
- Widely used for skiving all kinds of leather, synthetic leather, rubber, etc.

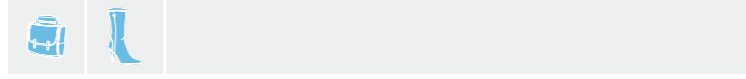

YXP-18

YXP-18	Skiving machine
YXP-28	Skiving machine(top and bottom feed)

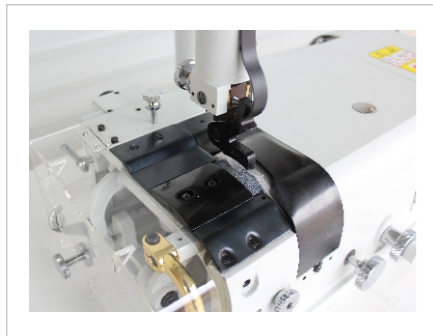













### STITCHTYPE

-  LOCKSTITCH 301
-  CHAINSTITCH 101 (1 THREAD)
-  CHAINSTITCH 401 (2 THREADS)
-  OVERLOCK
-  OVERLOCK 504
-  OVERLOCK 514 (2 NEEDLES)
-  SAFETY STITCH 516
-  ZIG ZAG
-  ZIG ZAG (3 STEP)
-  ZIG ZAG (4 STEP)
-  BUTTON SEWING
-  BUTTON HOLE SEWING
-  BAR TACK







### SPEED

-  MAX SEWING SPEED





### FEED TYPE

-  DROP FEED
-  NEEDLE FEED
-  DIFFERENTIAL TOP FEED
-  DIFFERENTIAL BOTTOM FEED
-  ALTERNATING TOP & BOTTOM FEED
-  2 TOP FEED STROKE VALUES RECALLABLE
-  ALTERNATING TOP, BOTTOM & NEEDLE FEED
-  DIFFERENTIAL FEED RATIO
-  X-FEED-TRANSPORT
-  BOTTOM & ROLLER PRESSER FEED
-  PULLER FEED
-  WHEEL & DRIVEN ROLLER PRESSER FEED
-  WHEEL, NEEDLE & DRIVEN ROLLER PRESSER













### STITCHES

-  STITCH LENGTH
-  SEAM WIDTH
-  ZIG ZAG WIDTH
-  NUMBER OF STITCHES
-  BUTTON SEWING: HOLE SIZE
-  BUTTON ATTACHING PATTERN

### NEEDLE

-  NEEDLE SYSTEM
-  NUMBER OF NEEDLES
-  NEEDLE BAR STROKE
-  NEEDLE GAUGE
-  SPLIT NEEDLE BAR

### HOOK

-  HORIZONTAL HOOK: EXTRA LARGE
-  HORIZONTAL HOOK: LARGE
-  HORIZONTAL HOOK: STANDARD
-  HORIZONTAL HOOK: SIZES
-  VERTICAL HOOK: EXTRA LARGE
-  VERTICAL HOOK: LARGE
-  VERTICAL HOOK: STANDARD
-  VERTICAL HOOK: SIZES
-  LOOPER HOOK CROSSLINE
-  LOOPER HOOK INLINE
-  BARELL HOOK
-  BUTTERFLY HOOK
-  SHUTTLE HOOK











### CYLINDER ARM

-  CYLINDER ARM DIAMETER



### FOOT LIFT

-  FOOT LIFT

### EQUIPMENT

-  THREAD TRIMMER
-  THREAD WIPER
-  THREAD NIPPER
-  EDGE TRIMMER
-  UNDER-EDGE TRIMMER
-  BACK TACK
-  AUTO BACK TACK
-  AUTO FOOT LIFT
-  PRESSER FOOT LIFT: KNEE
-  PRESSER FOOT LIFT: MANUAL
-  2 DIFFERENT STITCH LENGTHS

### MATERIAL

-  LIGHT MATERIAL
-  MEDIUM MATERIAL
-  HEAVY MATERIAL
-  MATERIAL THICKNESS
-  EXTRA HEAVY-DUTY
-  WORKING SPACE